

# Cyrix-ct 12/24 V 120 A and 230 A

Intelligent battery combiner

www.victronenergy.co.nz



Cyrix-ct 12/24-120



LED status indicator

Cyrix-ct 12/24-230



Control cable for  
Cyrix-ct 12/24-230  
Length: 1 m

## Intelligent battery monitoring to prevent unwanted switching

Some battery combiners (also called voltage controlled relay, or split charge relay) will disconnect a battery in case of a short but high amperage load. A battery combiner also may fail to connect a large but discharged battery bank because the DC voltage immediately drops below the disengage value once the batteries are connected. The software of the Cyrix-ct 12/24 does more than simply connect and disconnect based on battery voltage and with a fixed time delay. The Cyrix-ct 12/24 looks at the general trend (voltage increasing or decreasing) and reverses a previous action only if the trend has reversed during a certain period of time. The time delay depends on the voltage deviation from the trend.

(for Battery Combiners with multiple engage/disengage profiles, please see the Cyrix-i 400)

## Long bolts to allow connection of more than one power cable

Cyrix 12/24-120: 13 mm (M6)

Cyrix 12/24-230: 16 mm (M8)

## Protection against overheating (due to a long duration overload e.g.)

The Cyrix will disengage in case of excessive contact temperature, and reengage again after it has cooled down.

## LED status indication (Cyrix 12/24 230 only)

LED on: engaged

LED 10 s flash: disengaged

LED 2 s flash: connecting

LED 2 s blink: disconnecting

LED 0,25 s blink: alarm (over temperature; voltage > 16 V; both batteries < 10 V; one battery < 2 V) (multiply by two for 24 V)

## 12/24 V auto ranging

The Cyrix-ct 12/24 automatically detects system voltage.

## No voltage loss

Cyrix battery combiners are an excellent replacement for diode isolators. The main feature is that there is virtually no voltage loss so that the output voltage of alternators or battery chargers does not need to be increased.

## Prioritising the starter battery

In a typical setup the alternator is directly connected to the starter battery. The accessory battery, and possibly also a bow thruster and other batteries are each connected to the starter battery with Cyrix battery combiners. When a Cyrix senses that the starter battery has reached the connect voltage it will engage, to allow for parallel charging of the other batteries.

## Bidirectional voltage sensing and power supply from both batteries

The Cyrix senses the voltage of both connected batteries. It will therefore also engage if for example the accessory battery is being charged by a battery charger.

The Cyrix-ct 12/24 has a dual power supply. It will therefore also close if the voltage on one battery is too low to operate the Cyrix.

In order to prevent unexpected operation during installation or when one battery has been disconnected, the Cyrix-ct 12/24 will not close if the voltage on one of the two battery connections is lower than 2 V (12 V battery) or 4 V (24 V battery).

## Parallel connection in case of emergency (Start Assist)

The Cyrix can also be engaged with a push button (Cyrix remains engaged during 30 seconds) or a switch to connect batteries in parallel manually.

This is especially useful in case of emergency when the starter battery is discharged or damaged.

Cyrix Battery Combiner	Cyrix-ct 12/24-120	Cyrix-ct 12/24-230
LED status indication	No	Yes
Continuous current	120 A	230 A
Cranking rating (5 seconds)	180 A	500 A
Connect voltage	From 13 V to 13,8 V and 26 to 27,6 V with intelligent trend detection	
Disconnect voltage	From 11 V to 12,8 V and 22 to 25,7 V with intelligent trend detection	
Current consumption when open	<4 mA	
Current consumption when closed	12 V: 220 mA    24 V: 120 mA	12 V: 320 mA    24 V: 180 mA
Start Assist	Yes (Cyrix remains engaged during 30 seconds)	
Control cable included (length 1 m)	No	Yes
Protection category	IP54	
Weight kg (lbs)	0,11 (0,24)	0,27 (0,6)
Dimensions h x w x d in mm (h x w x d in inches)	46 x 46 x 80 (1.8 x 1.8 x 3.2)	65 x 100 x 50 (2.6 x 4.0 x 2.0)

Connect (V)	Delay
V < 13 V	Remains open
13,0V < V < 13,2V	10 min
13,2V < V < 13,4 V	5 min
13,4V < V < 13,6V	1 min
13,6V < V < 13,8V	4 sec

Disconnect (V)	Delay
V < 11 V	0 sec
11,0V < V < 12,0 V	1 sec
12,0V < V < 12,2 V	10 sec
12,2V < V < 12,4 V	30 sec
12,4V < V < 12,8 V	3 min
> 12,8 V	remains closed
> 16 V	over voltage disconnect

Approximate connect and disconnect delay  
(multiply by two for a 24 V system)

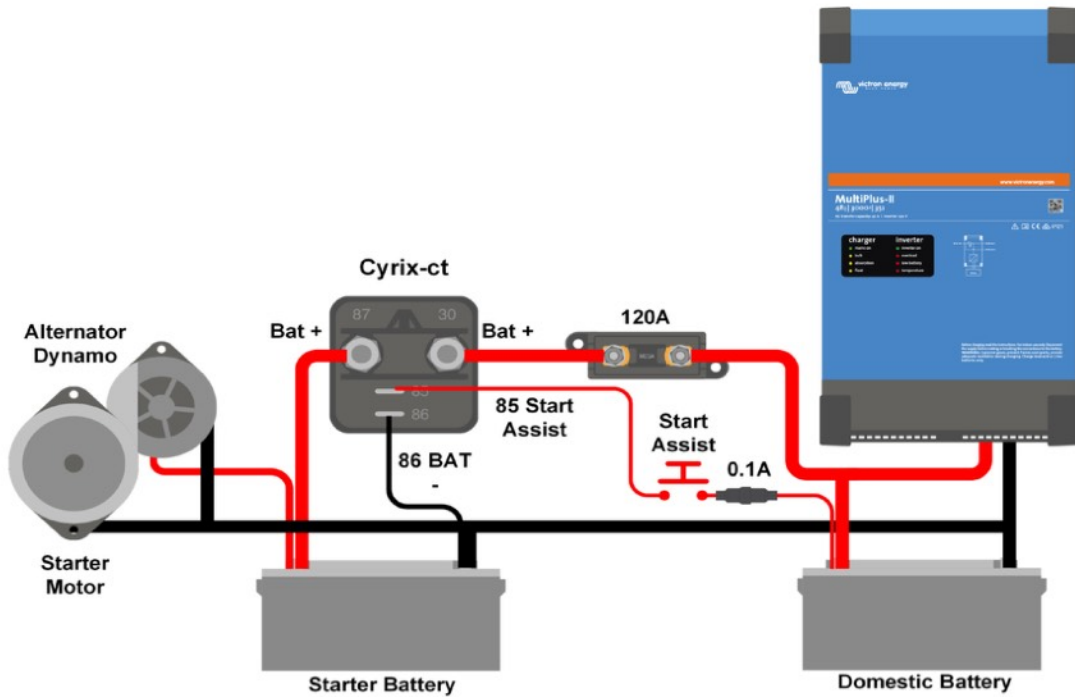

Cyrix-ct 12/24-120: connection diagram

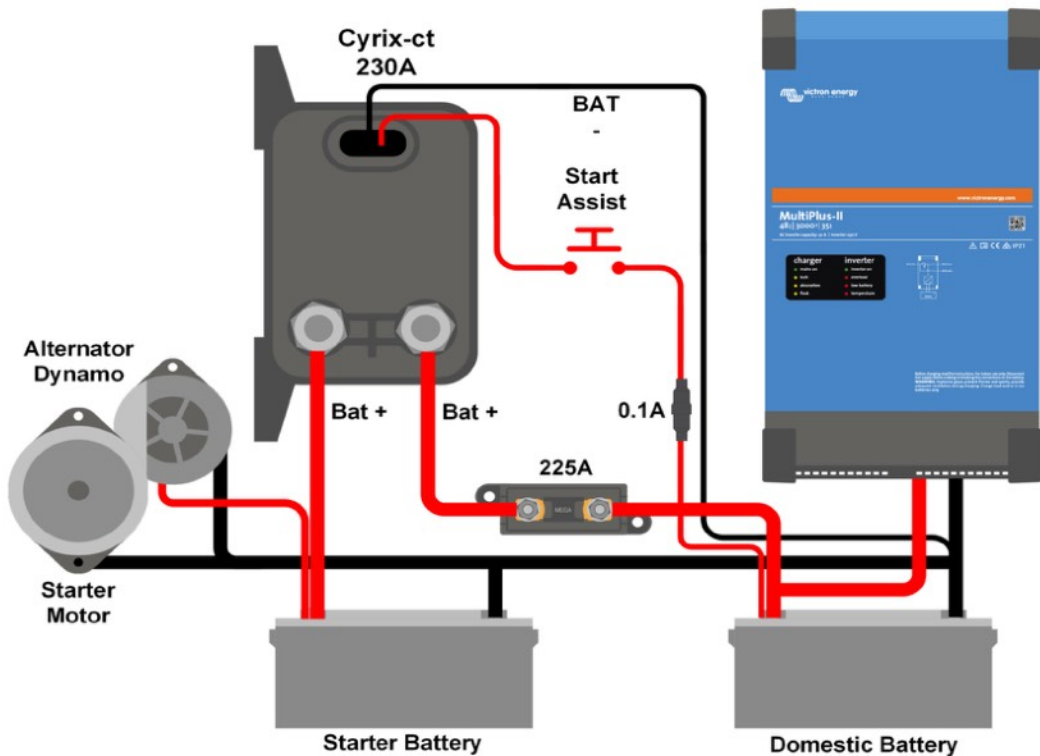

Cyrix-ct 12/24-230: connection diagram